

INSTALLATION INSTRUCTIONS

1. Place Assembly 1 into sockets on Assembly 2.
2. Fully tighten all 4 Socket Set Screws to secure.

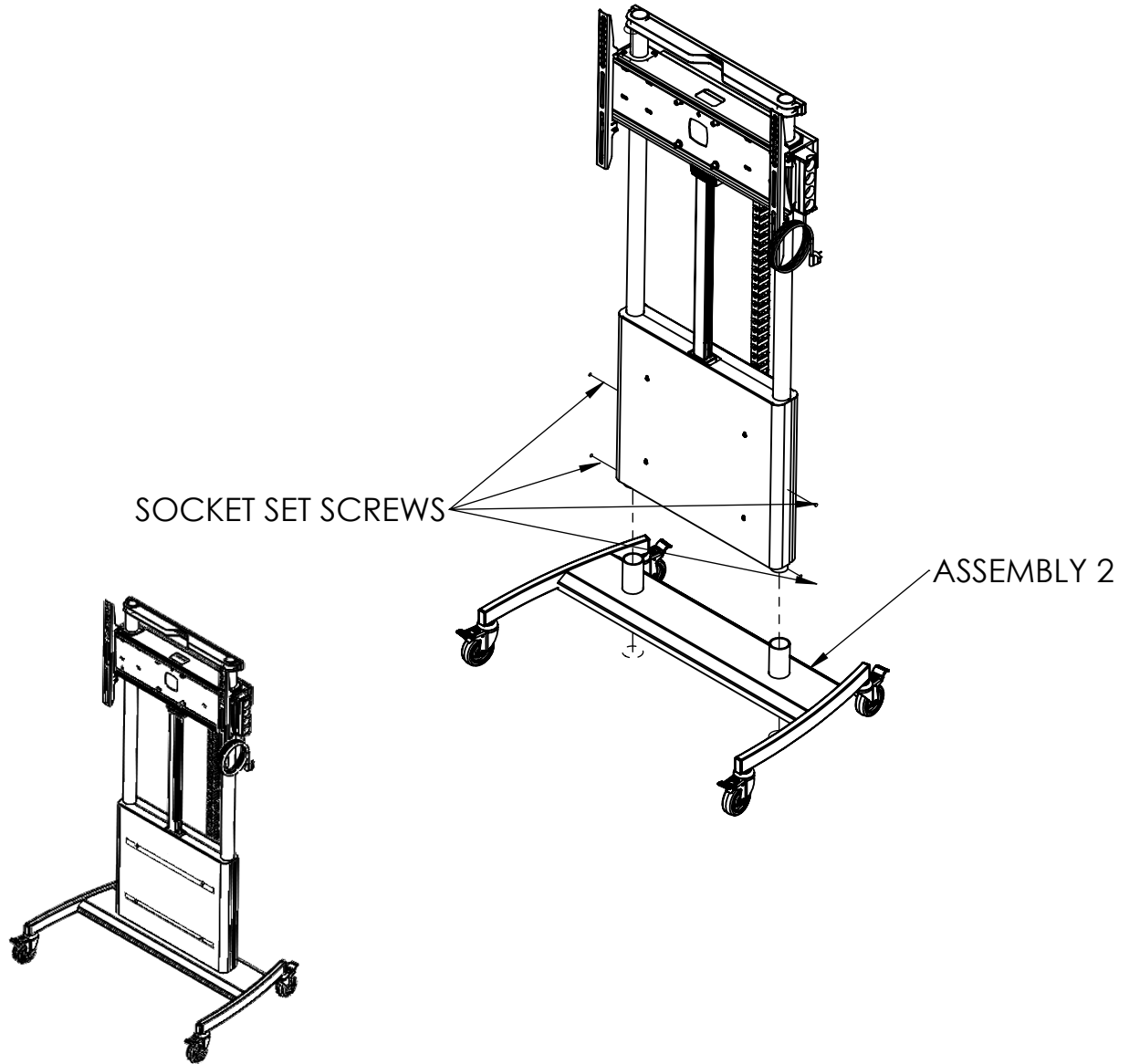

Inspect the unit before installing

Warning: Watch for pinch points. Do not put your fingers between moveable parts. Do not tamper with or dis-assemble any spring loaded items.

1. Carefully inspect the unit for shipping damage. If any damages apparent, call Unicol on number below.
2. Lay out components to ensure you have all the required parts before proceeding.

Caution: To prevent damage to the unit, study all instructions and illustrations before you begin the installation. Failure to do so could render the warranty for the unit and the equipment that attaches to it null and void. Pay particular attention to the “warnings” displayed in these instructions.

We recommend installation by a qualified tradesperson. If you have any questions about the installation, contact Unicol, (uk +44 (0) 1865 767676) (europe +49 (0) 9131 9405 8013).

